

Vector Velocimeter

High Resolution 3D
Current Meter

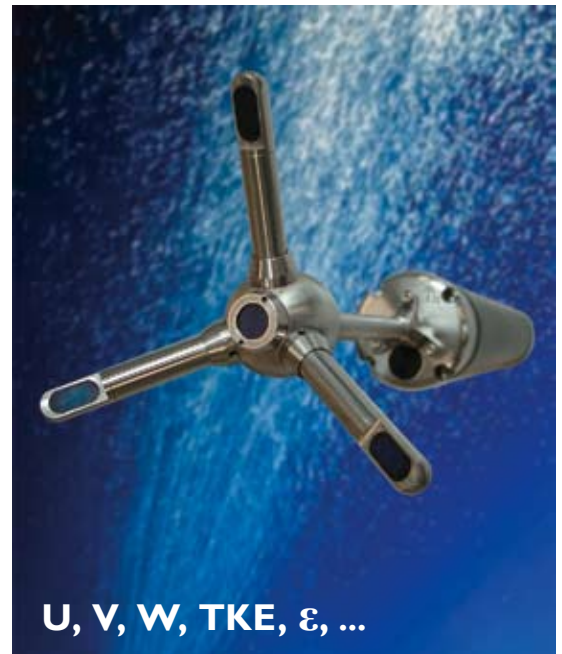

U, V, W, TKE, ϵ , ...

The Vector is an integrated 3D current meter designed for use in the ocean. The core of the Vector is an acoustic Doppler velocimeter, used to achieve accurate and nonintrusive velocity data at rates as high as 64Hz. The system comes standard with compass, tilt, pressure, and temperature sensors and it can be used both in self-contained and online mode.

Leading oceanographers, coastal engineers, and hydraulic engineers all over the world commonly use the Vector for a wide range of high-resolution applications. The most common uses are:

- ✓ Studies of surf-zone dynamics.
- ✓ Turbulence studies in rivers, estuaries, and coastal areas.
- ✓ Combined wave and current monitoring.

The Vector was designed from the outset as an integrated open water system. This gives the Vector some unique advantages:

- ✓ Single-canister system with internal memory and batteries.
- ✓ Small and light weight.
- ✓ Titanium probe and plastic canister provides mechanical strength and prevents corrosion.
- ✓ High resolution pressure sensor for PUV wave measurements.
- ✓ Two analog input lines permit easy integration with external OBS, conductivity or other analog sensors.

In most cases, the Vector is deployed as a self-contained instrument with internal recorder, or operated from an on-line PC. It can also be operated from any third-party controller using RS 232 or RS 422 communication.

For integration with other data acquisition systems the three analog outputs (one for each velocity component or two velocity components and pressure) can be used.

Wave directional spectra

The Vector can be configured to sample the high-resolution pressure sensor and the three velocity components at a rapid rate in user specified burst intervals. This type of data, known as wave triplet data, can be used to calculate the wave height, period, and direction.



www.nortek.no

Specifications

Water Velocity Measurement

Range	±0.01, 0.1, 0.3, 2, 4, 7 m/s (software selectable)
Accuracy	±0.5% of measured value ±1 mm/s
Sampling rate (output)	1–64Hz
Internal sampling rate	100–250Hz

Sampling Volume

Distance from probe	0.15 m
Diameter	15 mm
Height (user selectable)	5–20 mm

Doppler Uncertainty (noise)

Typ. uncertainty at 16Hz	1% of velocity range
--------------------------	----------------------

Echo Intensity

Acoustic frequency	6 MHz
Resolution	0.45 dB
Dynamic range	90 dB

Sensors

Temperature	Thermistor embedded in end bell
Range	–4°C to 40°C
Accuracy/Resolution	0.1°C / 0.01°C
Time response	10 min
Compass	Flux-gate with liquid tilt
Maximum tilt	30°
Accuracy/Resolution	2°/0.1°
Tilt	Liquid level
Accuracy/Resolution	0.2°/0.1° for tilt < 20°
Up or down	Automatic detect
Pressure	Piezoresistive
Range	0–20m (standard)
Accuracy/Resolution	0.25% / Better than 0.005% of full scale

Data Communication

I/O	RS232 or RS422. Software supports most commercially available USB–RS232 converters.
Baud rate	300–115200
User control	Handled via Vector Win32® software, ActiveX® function calls, or direct commands.

Analog outputs	3 channels standard, one for each velocity component or two velocities and pressure. Output range is 0–5V, scaling is user selectable.
----------------	--

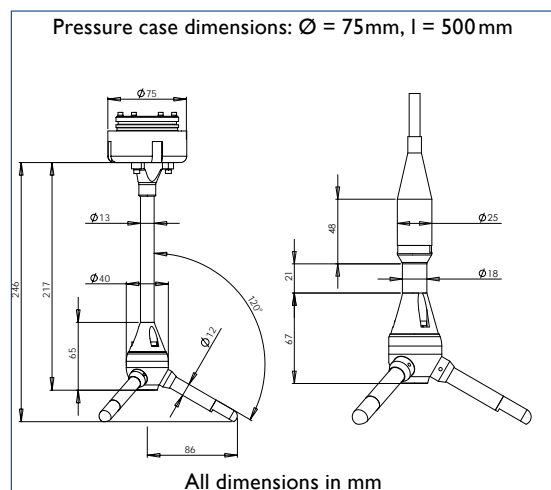

Analog Inputs

No. of channels	2
A/D converter	16 bit
Voltage output	Battery voltage, 5VDC or 12VDC (Specify on order)

Software (“Vector”)

Operating system	Windows®2000, Windows®XP
Functions	Deployment planning, start with alarm, data retrieval, ASCII conversion. Online data collection and graphical display. Test modes

Data Recording

Capacity (standard)	2MB, expandable to 26, 82, or 154MB
Data record	24 bytes at sampling rate + 28 bytes/second

Power

DC Input	9–16VDC
Peak current	2.5A at 12VDC (user selectable)
Max consumption, 64Hz	1.5W
Typ. consumption, 4Hz	0.6–1.0W
Sleep consumption	0.0013W
Battery capacity	50Wh
New battery voltage	13.5VDC
Data collection capacity	Refer to planning section in software

Connectors

Bulkhead (Impulse)	MCBH-8-FS
Cable	PMCIL-8-MP on 10-m polyurethane cable

Materials

Standard model	Delrin® housing. Titanium probe and screws
----------------	--

Environmental

Operating temperature	–5°C to +45°C
Storage temperature	–20°C to +60°C
Shock and vibration	IEC 721-3-2
Pressure rating	300m for canister.

Dimensions

Cylinder	$\varnothing 75\text{mm}$
Length	500 mm
Weight in air	5.0kg
Weight in water	1.5kg

Options

Acoustic beams	Probe mounted on fixed stem or on 2-m cable (see drawing)
Battery	See battery brochure
Pressure sensor	Specify range. Inquire for deep water version

www.nortek.no

NORTEK AS
Vangkroken 2
NO-1351 Rud
Norway

Tel: +47/ 6717 4500
Fax: +47/ 6713 6770

E-mail: inquiry@nortek.no

青岛诺泰克测量设备有限公司
地址: 中国青岛香港西路65号

汇融广场1302
邮编: 266071

Tel: 0532-85017570, 85017270
Fax: 0532-85017570

E-mail: inquiry@nortek.com.cn

NortekUK
Mildmay House, High St.
Hartley Wintney
Hants. RG27 8NY

Tel: +44- 1428 751 953
Fax: +44- 1428 751 533

E-mail: inquiry@nortekuk.co.uk

NORTEKUSA
222 Severn Avenue
Suite 17, Building 7
Annapolis, MD 21403

Tel: +1 (410) 295-3733
Fax: +1 (410) 295-2918

E-mail: inquiry@nortekusa.com
www.nortekusa.com